

**ferrum**

**ECO LINE PUSHER CENTRIFUGES  
BEST IN CLASS**



# SUCCESS NEEDS TARGETS OPTIMIZING PRODUCTION AND REDUCING COSTS

Centrifuges for solid-liquid separation are designed for a wide range of applications. However, the economic objective behind the processing procedure is the same everywhere: To keep production high without any loss of quality and to do so at low cost in the long term.



## INCREASING PRODUCTION

Increasing production not only leads to higher production volumes, but often also to increased efficiency. This requires production facilities that provide a solid foundation for increasing production. The Ferrum pusher centrifuge plays a crucial role here, as it helps to optimize production facilities and thus increase efficiency and output.



## REDUCING COSTS IN THE LONG TERM

Sustainable investments are not only future-proof, but also save costs in the long term. The secret lies in making an investment that not only creates value in the short term, but also lasts for years to come. This is where the Ferrum centrifuge becomes important. Our innovative solutions not only offer immediate benefits, but are also designed to deliver long-term cost savings. With proven efficiency and reliability, Ferrum centrifuges help keep operating costs low over the lifetime of your investment.



## OPTIMIZING PROCESSES

The key to a successful production process is to maximize the performance of all components. In this respect, optimization plays a crucial role by ensuring that every element in the chain is working to its full potential. This is exactly where Ferrum pusher centrifuges come into play. Thanks to their proven efficiency and reliability, they help to boost performance in your production chain.



## MAINTAINING QUALITY

Increasing production, optimizing processes and reducing downtime? By all means, but this should not be at the expense of quality. After all, maintaining quality also means securing sales in the long term.

# SPECIFICALLY IMPLEMENTING WHAT YOU NEED

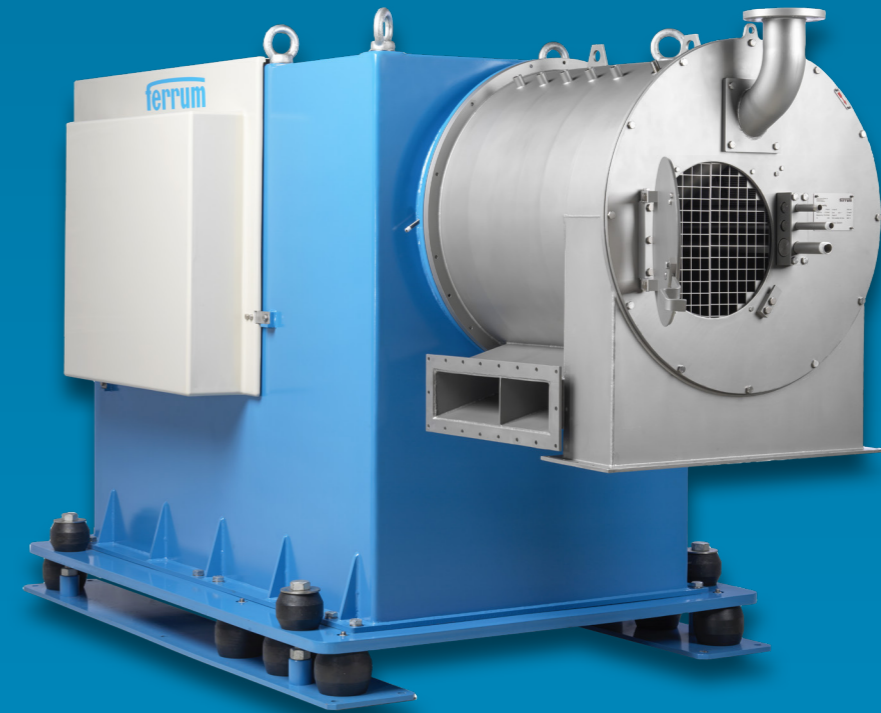

## ECO LINE BRINGS “FERRUM QUALITY” TO THE WHOLE WORLD

Ferrum machines are known worldwide for their reliability. Over 100 years of experience go into every machine. And you can see that in our machinery: Top quality at all levels and standard designs lead to needs-based and sustainable solutions. That is why many of the world's largest companies put their trust in our centrifuges. They all also appreciate our global service and fast spare parts delivery.

## FERRUM PROCESS SYSTEMS – CENTRIFUGE TECHNOLOGY AT ITS BEST

We are one of the world's leading manufacturers of industrial centrifuges for solid-liquid separation. Our many customers from different industries vouch for the quality and variety of our solutions for dynamic separation processes. If you work with us to perfectly integrate a Ferrum centrifuge into your process, you'll receive a promise that pays dividends: A worthwhile investment in the long term that does not neglect quality, even when under high pressure.



# 7 REASONS WHY WE ARE YOUR TRUSTED CENTRIFUGE PARTNER SINCE 1935

We deliver Swiss quality made in India. Our legacy of excellence spans generations, and our satisfied customers from a wide array of industries can attest to the top quality and versatility of our centrifuges for dynamic separation processes.

Here is why choosing Ferrum for your centrifuge needs is a decision you will not regret:

## 1. SWISS ENGINEERING MADE IN INDIA

Our commitment to incorporating Swiss excellence into every aspect of production ensures that every Ferrum centrifuge combines Swiss precision with the cost efficiency of Indian manufacturing.

## 2. FAST SERVICE SUPPORT

Your time is valuable, and we understand that. That is why our dedicated service support team is always at your disposal, ready to assist you promptly whenever you need it.

## 3. OPTIMAL PERFORMANCE

Choose Ferrum for more than just a centrifuge - take advantage of the expertise of our experienced staff. Our knowledge guarantees that your centrifuge works at optimum performance.

## 4. OUTSTANDING RELIABILITY

Carefully manufactured centrifuges to meet international standards for unbeatable quality and reliability.

## 5. YOUR TRUST IS OUR COMMITMENT

Count on us to deliver on our promises and provide solutions that meet your specific needs.

## 6. BEST PARTNER BONDS

We believe in nurturing strong, long-lasting relationships with our customers. Your satisfaction is our priority.

## 7. AFFORDABLE SOLUTIONS

We understand the importance of affordability, and our commitment to providing solutions ensures that you get the best value for your investment.





# DETAILS THAT MAKE A DIFFERENCE

Pusher centrifuges are continuously operating filter centrifuges and depending on the application have one or two basket stages. Product details are shown here on a Ferrum centrifuge P-500.

## PURITY ENHANCEMENT

Impurities in the mother liquor are removed by applying wash liquid continuously through adjustable nozzles over the cake.

## EFFICIENT LIQUID REMOVAL

Approximately 80% of the liquid is filtered out in the feed zone of the first basket stage, forming a stable cake. The first basket stage acts both rotational and axial movements, including an oscillation movement.

## IMPROVED FEEDING CONTROL

Suspension inlet: The centrifuge is continuously fed with suspension via the inlet pipe. A screw conveyor is used for products with a high solids concentration.

## EFFICIENT MATERIAL HANDLING

Each pusher movement from the first to the second basket pushes the cake in annular sections.

## CUSTOMIZED DISCHARGE

The solids exit the centrifuge through the discharge track and housing after the second basket stage. We provide tailored discharge channels to meet your specific needs and application requirements.

## OPTIMAL FILTRATE ROUTING

The filtrate, consisting of filtered mother liquor and wash liquid, is collected and drawn off through various filtrate housings and cyclones depending on the application.

## UNIFORM DISTRIBUTION

Ferrum offers various distributor systems for specific applications that ensure uniform acceleration and distribution of the suspension and keep crystal breakage at a minimum.

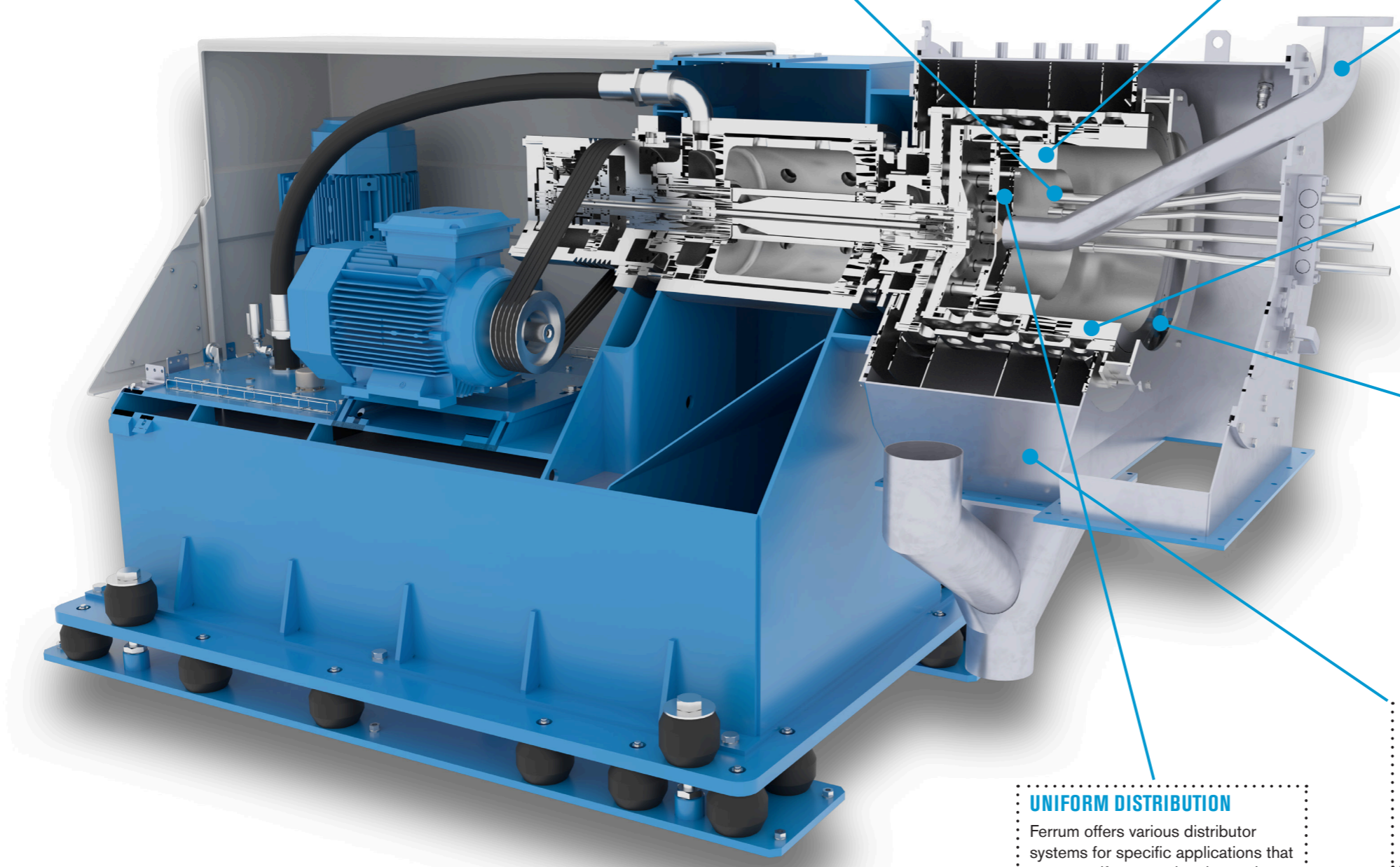

# PRE-THICKENING AN IMPORTANT WORKSTEP

As a continuously operating machine, the pusher centrifuge requires process conditions and solids concentrations as constant as possible to ensure optimum operation and consistent product quality.

For the process and plant-related reasons, the necessary feed conditions are often not achieved. As a solution for this problem, Ferrum therefore offers various pre-thickening systems and dosing devices.

Depending on requirements, Ferrum supplies the design, production and automation of the related system.

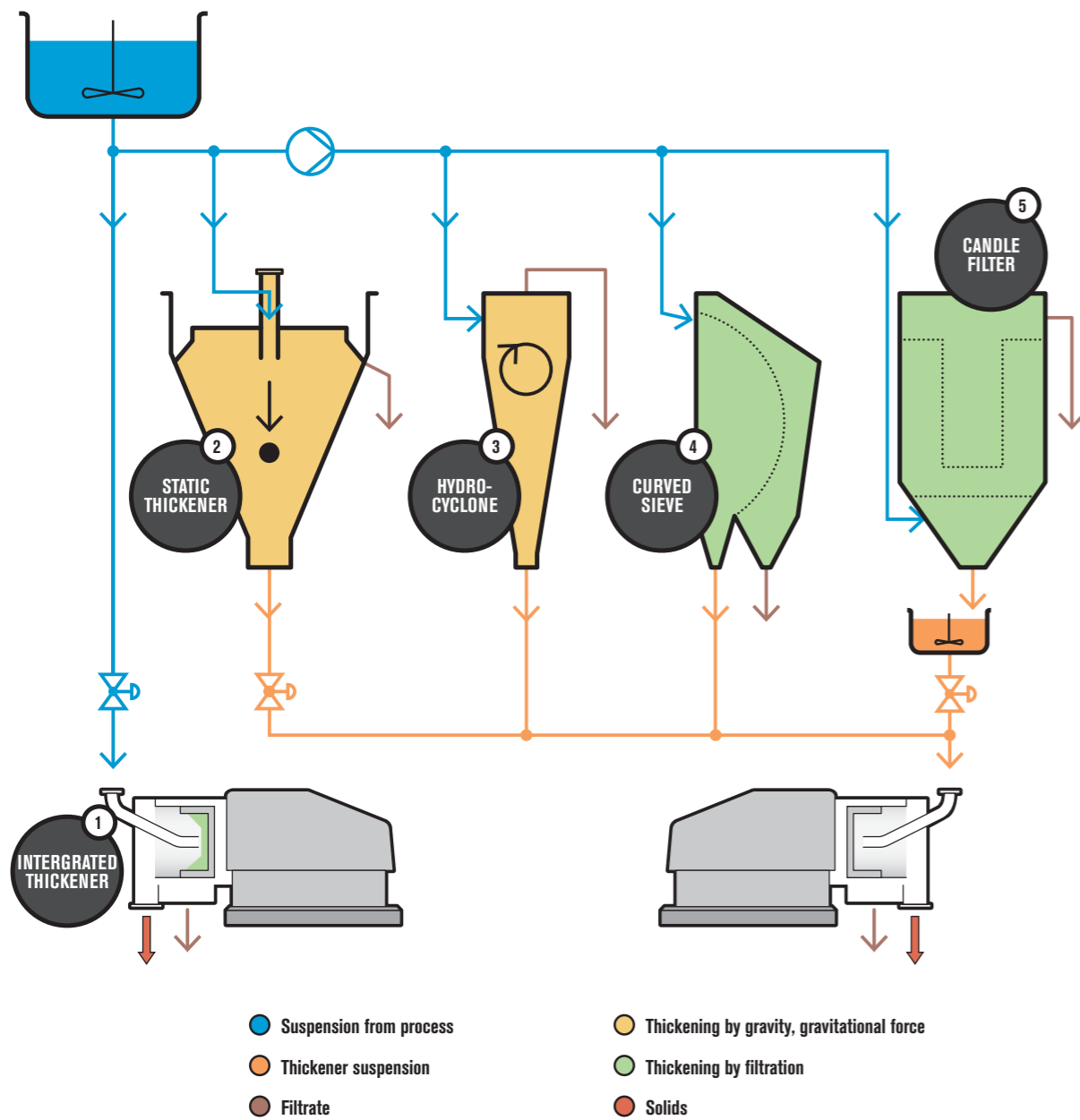

# INTEGRATED THICKENER A FERRUM INNOVATION

The integrated thickening cone for pusher centrifuges was developed and patented by Ferrum. Depending on the application separate external pre-thickening is not required. Fluctuating feed concentrations are compensated, cake formation is improved and the product is accelerated more gently. Today for certain applications the integrated thickening cone is our standard.

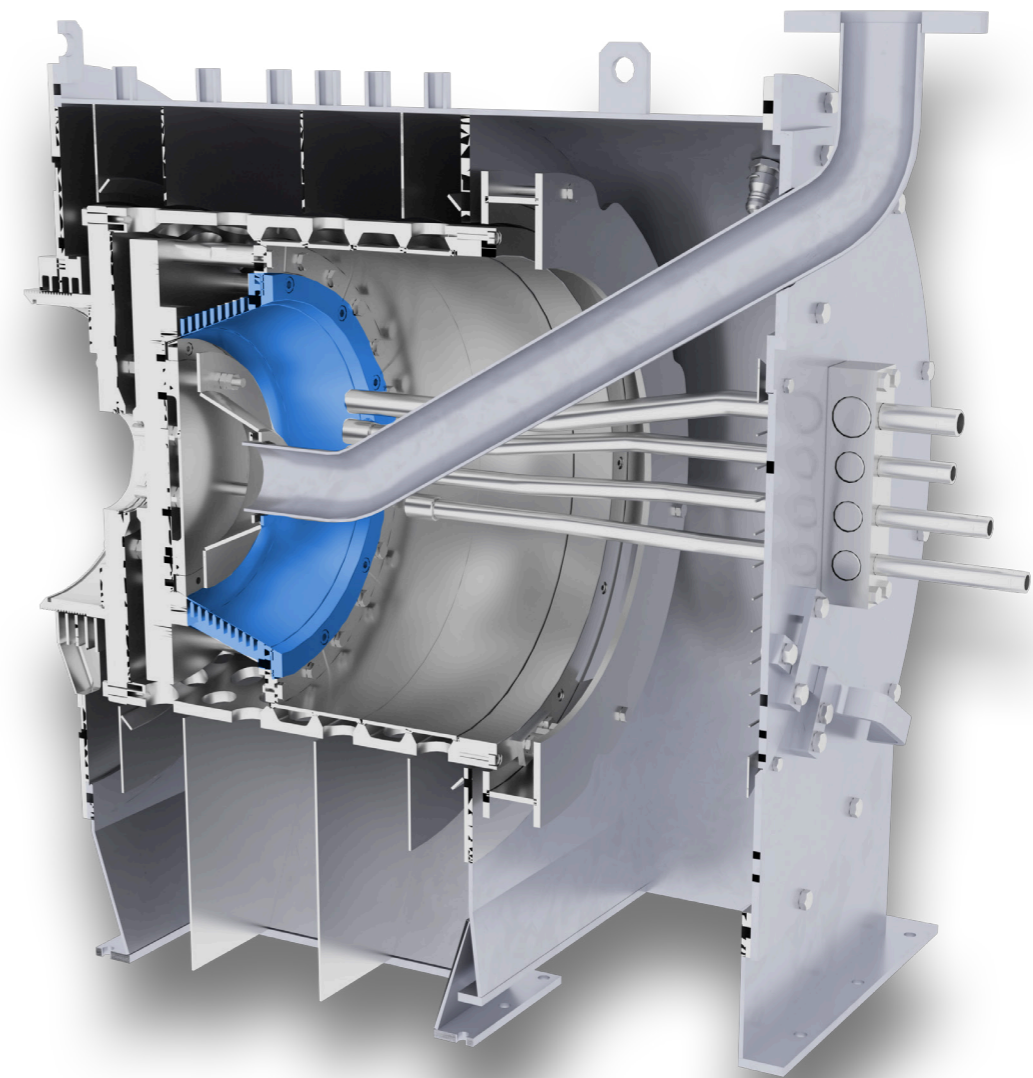



# MECHANICAL DESIGN

## PM-230

Based on the very successful design, Ferrum has consistently developed this pusher centrifuge further, always in accordance with the latest requirements and guidelines. The PM-230 guarantees best solid-liquid separation with high and constant product quality.

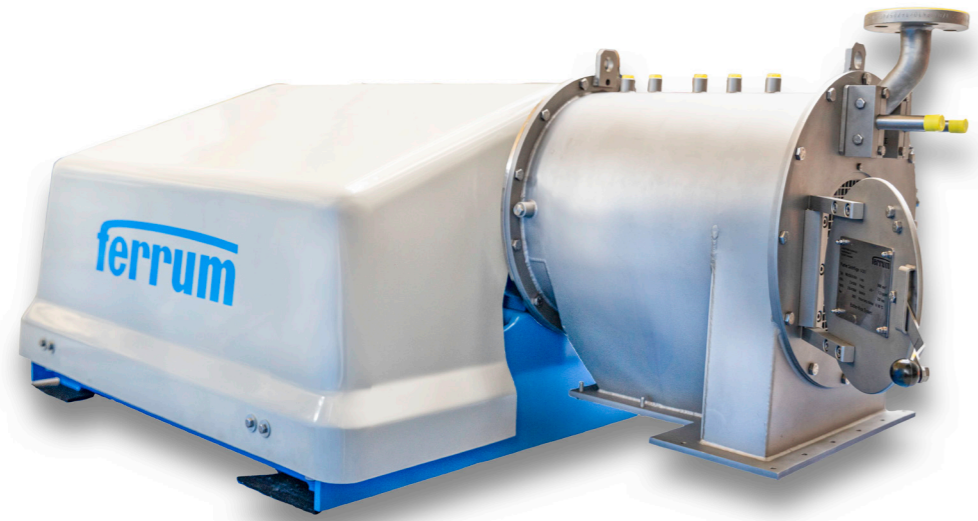

### PM-230

- + **Pusher centrifuge**
  - Mechanical push drive, without a hydraulic system
  - Application-specific optimization possibilities: Inlet and outlet section, screen segments, solid discharge, product washing, etc.

### APPLICATIONS

- + **Basic Products**
  - Calcium tartrate
  - Sodium carbonate
  - Sodium chloride
  - Proteins
  - Sodium bicarbonate
  - Calcium phosphate
  - Rock salt (NaCl), Sea salt
  - Adipic acid
  - Bisphenol A
  - To mention the most frequently used

### AVAILABLE SIZES

- + **Pusher Centrifuge**
  - PM-230

# HYDRAULIC DESIGN

## P-360 – P-1000

Our centrifuges for the petrochemical industry meet the highest safety standards. Thanks to their robust and reliable design, Ferrum centrifuges guarantee long and trouble-free operation. This enables cost-effective production and increases the efficiency of your plant, not least thanks to the proven Ferrum technology.



### P-360 – P-1000

- + **Pusher centrifuge**
  - Hydraulic push drive for high pushing forces.
  - Application-specific optimization possibilities: Inlet and outlet section, screen segments, solid discharge, product washing, etc.
  - Low oil pressures and a robust design enable Ferrum pusher centrifuges to provide long-lasting, reliable performance even in the harshest conditions.

### APPLICATIONS

- + **Basic Products**
  - Sodium chloride
  - Sodium sulphate
  - Ammonium sulphate
  - Ammonium nitrate
  - Potassium sulphate
  - Potassium nitrate
  - Nickel sulphate
  - Potassium chloride
  - Urea
  - To mention the most frequently used

### AVAILABLE SIZES

- + **Pusher Centrifuges**
  - P-360
  - P-500
  - P-630
  - P-1000

# MECHANICAL DESIGN

## PM-230

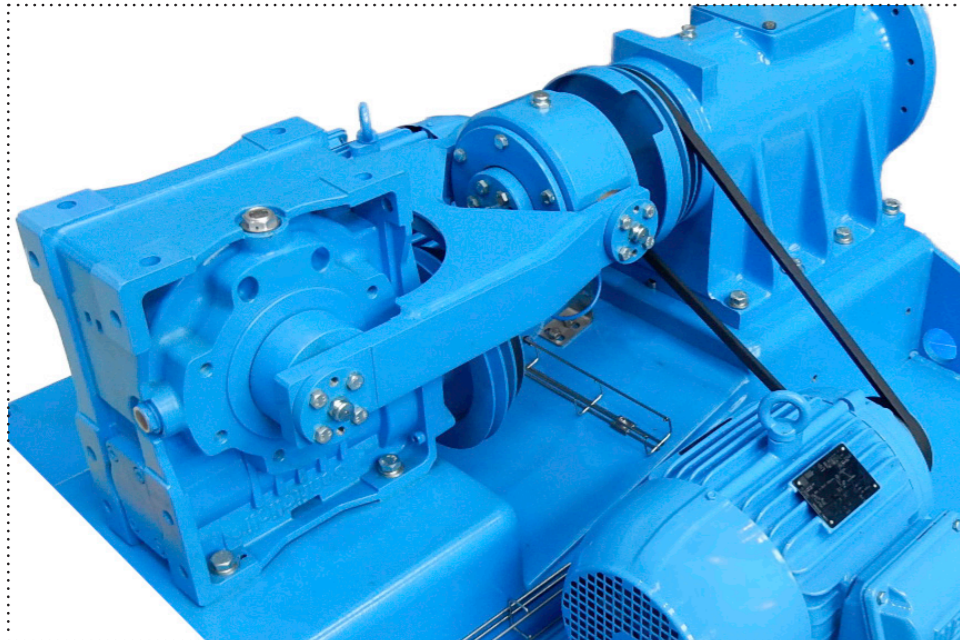

### DIMENSIONS

Pusher Centrifuges	PM-230	Unit
<b>L</b>	1'700	(mm)
<b>W</b>	1'200	(mm)
<b>H</b>	800	(mm)

### TECHNICAL DATA

Pusher Centrifuges	PM-230	Unit
<b>Basket diameter</b>	230	(mm)
<b>Number of stages</b>	1-2	-
<b>Max. Rotor speed</b>	3'200	(min-1)
<b>Max number of strokes</b>	100	(min-1)
<b>Max. G-force</b>	1'316	(g)
<b>El. power installed with NaCl rotor / stroke</b>	4/3	(kW)
<b>Weight</b>	800	(kg)
<b>Max. NaCl throughput / dependent on feed conditions)</b>	1.5	(t/h)

# HYDRAULIC DESIGN

## P-360 – P-1000

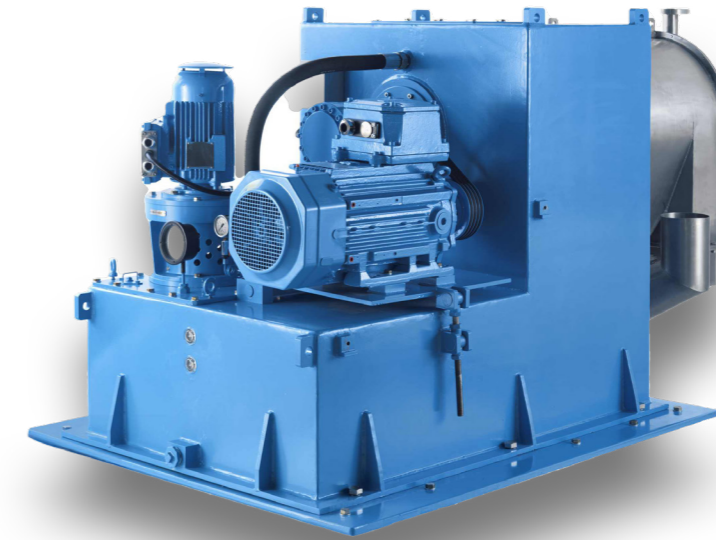

### DIMENSIONS

Pusher Centrifuges	P-360	P-500	P-630	P-1000	Unit
<b>L</b>	2'700	3'550	3'630	3'600	(mm)
<b>W</b>	1'400	1'420	2'000	2'000	(mm)
<b>H</b>	1'250	1'640	1'770	1'770	(mm)
<b>Height vibration isolation without counterweight</b>	1'400	1'800	1'970	2'425	(mm)

### TECHNICAL DATA

Pusher Centrifuges	P-360	P-500	P-630	P-1000	Unit
<b>Basket diameter</b>	360	500	630	1'000	(mm)
<b>Number of stages</b>	1 - 2	1 - 2	2	2	-
<b>Max. Rotor speed</b>	3'000	2'200	1'500	1'200	(min-1)
<b>Max number of strokes</b>	100	85	85	76	(min-1)
<b>Max. G-force</b>	1'810	1'352	792	559	(g)
<b>El. power installed with NaCl rotor / stroke</b>	11/75	22/15	45/22	37/110	(kW)
<b>Weight</b>	3'500	5'300	7'000	9'400	(kg)
<b>Maximum NaCl throughput / dependent on feed conditions)</b>	7	13	25	60	(t/h)

# AFTERSALES SERVICE FAST AND RELIABLE

Our experienced consultation teams are there for you worldwide: Highly qualified and with a personal touch custom-tailored to your specific needs. Contact us and we will be more than happy to put you in touch with the right contact person.

## SERVICE

A large team of experienced service specialists as well as various service centres are available to our customers worldwide. This ensures we can provide a fast and uncomplicated service.

- + Prompt and uncomplicated support from our customer service team
- + Worldwide service centres
- + Maintenance, inspections, maintenance contracts
- + Modifications, upgrades and integration of new drive and control systems
- + Customer-specific training

## REMOTE SERVICE

Count on quick and competent support in any situation with Ferrum Remote Service. Our experts will help you ensure quality and safety all day, every day so you achieve your process goals.

- + Fast, safe commissioning
- + Experienced troubleshooting
- + Expert process and systems control

## SPARE PARTS

You can count on high availability and short delivery times through an extensive and careful stock management of spare parts on our various sites worldwide.

- + Reliable service worldwide
- + Competitive prices
- + Top manufacturer quality
- + Original parts only



# FERRUM PROCESS SYSTEMS GLOBAL SUPPORT, WHEREVER YOU ARE



- LOCATIONS
- REPRESENTATIVES
- SERVICE PARTNER

## FERRUM PROCESS SYSTEMS LTD.

Industriestrasse 11  
5503 Schafisheim  
Switzerland  
T +41 62 889 14 11  
centrifuges@ferrum.net

## HILLER GMBH

Schwalbenholzstrasse 2  
84137 Vilsbiburg  
Germany  
T +49 8741 48 0  
info@hillerzentri.de  
www.hillerzentri.de

## FERRUM PROCESS SYSTEMS INC.

11414 W. Park Place  
Suite 202  
Milwaukee, WI 53224  
USA  
T +1 877 933 3778  
sales@ferrumus.com

## FERRUM POLAND SP. Z O.O.

ul. Powstańców Wlkp. 23  
64-510 Wronki  
Poland  
T +48 67 25 40 561  
contact@ferrum.net

## FERRUM PROCESS SYSTEMS (KUNSHAN) CO., LTD.

No. 329, Jujin Road  
Zhangpu Township  
215321 Kunshan City  
Jiangsu Province  
P.R. China  
T +86 512 3662 5403  
centrifuge@ferrumchina.com

## FERRUM TECHNOLOGIES INDIA PVT LTD.

W - 29D, Additional Ambarnath MIDC  
Ambarnath - 421 506  
India  
T +91 251 262 0202  
nitin.kamble@ferrumin.com



## FURTHER INFORMATION ONE CLICK AWAY



### CENTRIFUGE TECHNOLOGY

Everything you need to know about your application with our centrifuges.

▶ [ferrum.net/centrifuge](https://ferrum.net/centrifuge)

### SERVICE AND ACCESSORIES



▶ [ferrum.net/centrifuge-service](https://ferrum.net/centrifuge-service)

### CONTACT NEW MACHINES



▶ [ferrum.net/centrifuge-contact](https://ferrum.net/centrifuge-contact)