

# SCRAPER CENTRIFUGE VBC-W 1600/1000

## ROBUSTE, MODULAR, RELIABLE

Take advantage of our reconditioned used machine now: With a short delivery time as well as 12 months warranty, we offer you an interesting alternative to a new machine at a very attractive price.



### VBC-W 1600/1000 Vertical Scraper Centrifuge

The VBC model (Vertical Bottom discharge Centrifuge) has a wide range of applications in solid-liquid separation due to its versatile modularity.

Thanks to their exemplary efficiency, this scraper centrifuge can be used continuous operation in the chemical, fine chemical and pharmaceutical industries.

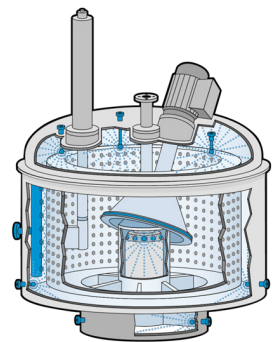
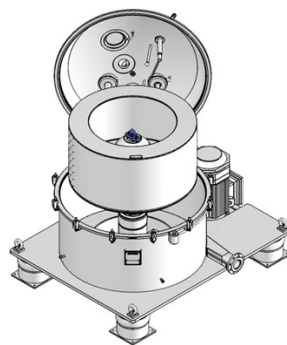
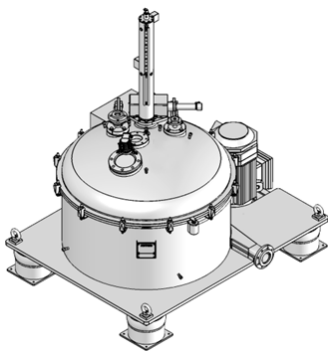

### ROBUSTE DESIGN

- + Functional parts optimally designed
- + Complies with current GMP standards
- + Field proven design

### MODULAR STRUCTURE

- + Can be retrofitted with Residual Heel Removal and Ex-Protection
- + Guaranteed spare parts stock
- + Easy to maintain

### CLEANING SYSTEMS

- + CIP-System
- + Possible flooding of the process area (optional)
- + GMP design for efficient cleaning

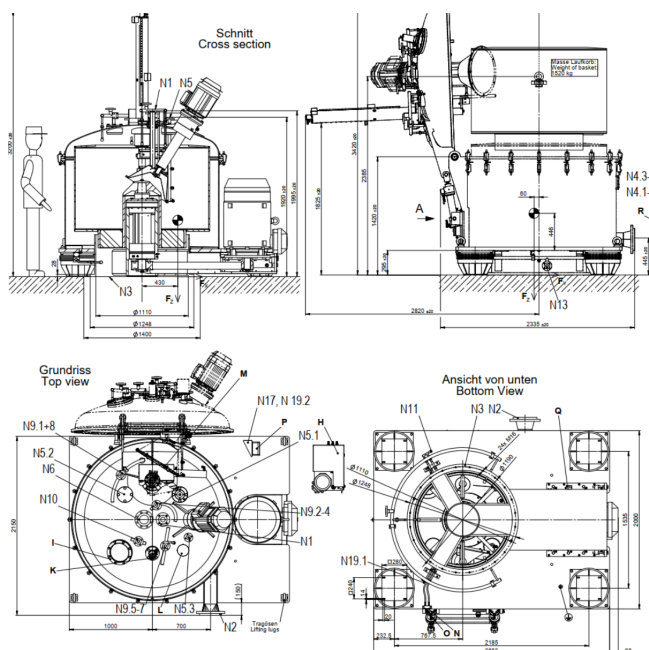

<b>Basket diameter</b>	1'600 mm
<b>Basket height</b>	986 mm
<b>Filter area</b>	4.96 m <sup>2</sup>
<b>Useful volume (100%)</b>	1'011 dm <sup>3</sup>
<b>Max. load</b>	1'263 kg
<b>Max. speed</b>	750 min <sup>-1</sup>
<b>Max. centrifugal acceleration</b>	503 g
<b>Gas tightness</b>	40 mbarg
<b>Main drive</b>	45 kW
<b>Frequency converter</b>	75 kW
<b>Control system</b>	CSS Basic

Dimensions max (mm)			Weight max (kg)	
Length	Width	Height	Centrifuge (without filling)	Heaviest part revision
2'900	2'250	2'200	10'400	2'085

## MACHINERY EQUIPMENT

### + Execution

- Material AISI 316 L
- Surface PB ground Ra < 0.8 µm
- Surface NPC ground Ra < 1.6 µm
- Without Ex-Protection
- EU Declaration of Conformity (CE)

### + Product entry

- Filling tube: Preparation
- Inclined feed and wash disc

### + Level monitoring

- Fill level control: digital

### + Washing device

- Solids washing device

### + Scraper unit

- Scraper unit: hydraulically driven

### + Process area cleaning

- Process area cleaning for lid and solids discharge
- CIP welded

### + Components

- Hydraulic unit for centrifuge cover and scraper unit

### + Tools

- Pin for tension ring / lifting device

### + Drive equipment

- Three-phase motors
- Frequency converter with regenerative braking unit

### + Safety and control equipment

- Control System Scraper (CSS) Basic
- Remote maintenance module

### + Documentation

- Documentation Ferrum Standard

